



PNEUMATIC PRODUCTS

NRG-LES Waste Heat Dryer (1000-9400 scfm)

Turn Waste Heat Into Energy Savings!!

- Low Outlet Dewpoint
- Minimum Purge Loss
- Minimum Energy Cost
- No Booster Heaters

DESCRIPTIONS

PPC's NRG-LES Waste Heat Dryer uses the heat from the compressor outlet to regenerate the off-stream desiccant bed. The patented* PPC design combines Heatless and Heated dryer technology to produce low outlet dewpoints without booster heaters.

Innovative adsorption technology, combined with PPC's superior state-of-the-art components, **yields the most energy efficient and reliable dryer in today's competitive market.**

NRG-LES Dryer produces line pressure dewpoints which meet or exceed the ISA requirement for outdoor air systems.

The NRG-LES Dryer comes standard with PPC's patented* and field proven AMLOC® control. AMLOC® maximizes the time between tower changeover, extending desiccant and component life.

Standard features of the controller include:

- High Humidity Alarm
- Switching Failure Alarm
- Status Lights
- Panel Mounted Pressure Gauges
- Regeneration Temperature Gauges

APPLICATIONS

The NRG-LES Dryer can ONLY be used with non-lubricated compressors. The dryer was designed to prevent water condensation in compressed air systems where constant -40°F pressure dewpoints are not required. Optimum dryer performance is obtained with compressor outlet temperatures above 285°F and cooling water temperatures below 85°F.



* Dryer design patent #4,783,432
Amloc design patent #4,552,570

HOW IT WORKS

Hot air from the compressor discharge is directed to the regenerating chamber through the three-way inlet valve. This air provides enough energy to release moisture from the desiccant. The relative humidity is low enough to create the needed differential to carry off the liberated moisture, allowing bulk water removal.

The hot, wet gas leaving the chamber passes through the water-cooled heat exchanger, where the temperature is lowered and much of the water condenses. A coalescing separator removes the entrained liquid.

The liquid-free, but saturated air, is then directed to the drying chamber where the water vapor is removed. The dry air exits the dryer and passes through an afterfilter which removes any particulates. The clean, dry air then passes into the plant air system.

Following the heating phase, the full inlet flow is diverted to the cooler and the drying chamber. The regenerating chamber is depressurized and swept with dry purge air from the outlet of the dryer. The dry purge strips residual moisture from the desiccant, allowing better dewpoint production. Due to evaporative cooling, the desiccant bed is cooled as moisture is removed. When the sweep phase is complete, the chamber is re-pressurized. Regeneration is now complete.

The drying chamber remains on-line until the AMLOC® probe senses that the desiccant has reached its maximum capacity. At this point, switching occurs and the cycle is reversed.

The combination of heating and sweeping reduces the desiccant bed temperature, minimizing any dewpoint rise at switchover.

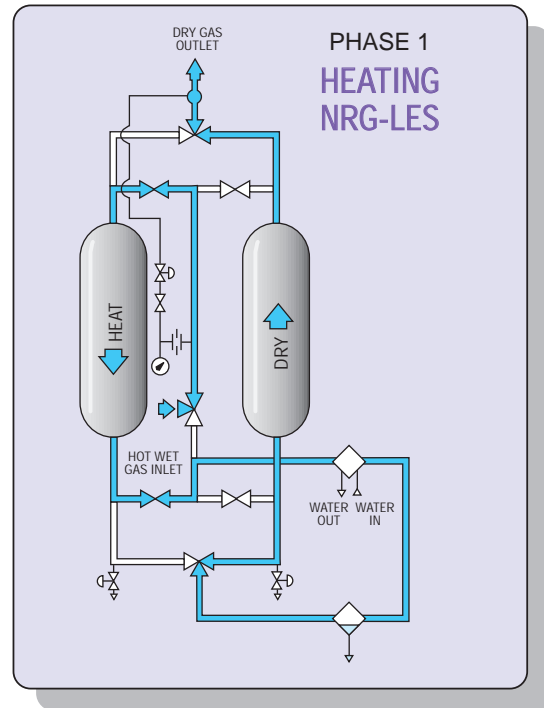

NRG-LES Flow Schematics

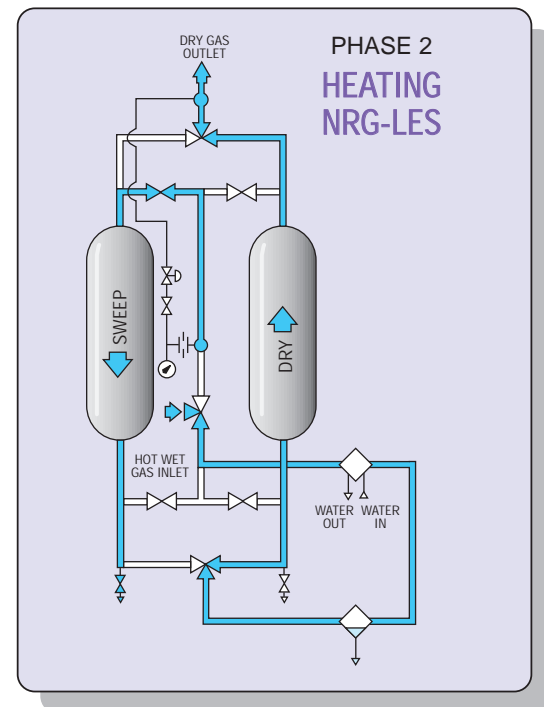

NRG-LES FEATURES AND BENEFITS

Over 35 Features That Surpass Other Commercially Available Systems

VESSELS

- ASME coded, manufactured in-house - Quality control
- 150# design with 1/16" C.A. - Long life
- SST inlet diffuser screens - Removable for ease of service and replacement
- All exposed steel shot-blast - Meets clean painting Specifications SSPC-SP6
- All steel primer coated for corrosion resistance
- Top coat two-part epoxy paint for a chip/scratch resistant finish

VALVES

- Patented poppet-style valves for friction and wear resistance - Reliability
- SST Internals for corrosion/erosion resistance - long life, low maintenance
- Viton high-temp seals for bubble tight integrity and resistance to temperature
- Permanent Dry-Lube - No lubrication required, low maintenance
- Cycle tested to 500,000 cycles - Reliability, long life
- Switching valves are pilot operated for positive and reliable cycling
- Self cleaning - Reduces wear due to contaminants, stick free
- Fully ported for low pressure drop
- No special tools required

CONTROLS

- Modular industrial grade components - Easy and cost effective component replacement
- Controller standard with AMLOC® Energy Management System

STANDARD DIAGNOSTICS:

- Power On, Chamber Drying (L/R), Valve Malfunction, AMLOC® System Check, High Humidity Warning, Heating, and AMLOC® hold.

CPU CONTROL BOARD:

- 2-Stage Logic Power protects CPU board
- 24 VDC Switching Power Supply for safety and efficiency
- Control Chip industry proven - Used in 80% of industrial applications

- Dip Switches allow for easy configuration of operational needs
- Watch-Dog Power Monitor prevents scramble or lock up
- High Intensity LED's for easy reading

SOLENOIDS - Long Life/Reliability

- 24 VDC Low voltage - Last longer
- Modular - Easy replacement
- Valve Position Indicators - Diagnostics
- Manual Override - Troubleshooting
- Cycle Tested 5,000,000 cycles - Long Life

PRESSURE SWITCHES - Long Life/Reliability

- High Grade Gold Plated Contacts
- 10,000,000 CycleTest - Long Life
- All Components UL/CSA Approved
- Controller fully tested and burned in on a 24-Hour Test at 140°F, exercised every 25 seconds, to ensure start-up reliability and long life

INSTRUMENTATION

- 2-1/2" Inlet/Outlet Pressure Gauges - Diagnostics
- 2-1/2" Chamber Pressure Gauges - Diagnostics
- Panel Mounted for easy access and reading
- 3" Regeneration Temperature Gauges for operation and diagnostics
- AQUADEX® Moisture Indicator - Back-up to high humidity alarm
- 0.9 micron (absolute) Pilot Air Filter - Protects Pneumatic Logic

HEAT EXCHANGER

- 10°F Approach Extended Surface
- Compact Single Pass

SEPARATOR

- Stainless steel self-cleaning demister pad
- Carbon steel ASME Code Vessel
- Coalescer Performance - No cartridges to change

DRAIN

- High capacity DDV-2000 piloted, float type - reliability
- Continuous water seal - no air loss

ENERGY COMPARISONS

NRG-LES Waste Heat Dryer to Other Dryer Types

	DESIGN CONDITIONS	AVERAGE CONDITIONS
FLOW (SCFM)	2,000	1,500
PRESSURE (PSIG)	100	100
TEMP. (F)	100°	100°
KWH	\$.05	\$.05

DRYER TYPE	ENERGY COST/YR.*
Heaterless	\$18,000.00
Atmospheric Blower	\$10,000.00
Multi-Internal Heater Tube	\$7,700.00
Exhaust Purge	\$7,000.00
NRG-LES	\$1,800.00

* Based on \$.05 kilowatt hour

PPC NRG-LES MODELS

MODEL	FLOW* (SCFM)	LINE SIZE	LB. DESICCANT PER CHAMBER	SWEEP (SCFM)	AFTERFILTER MODEL
1000 NRG-LES	1,000	3" FLG	410	50	PCC112001HT49
1500 NRG-LES	1,500	4" FLG	532	75	PCC118003HT65
1800 NRG-LES	1,800	4" FLG	655	90	PCC136003HT97
2300 NRG-LES	2,300	4" FLG	901	115	PCC136003HT97
2800 NRG-LES	2,800	6" FLG	1,106	140	PCC136003HT97
4000 NRG-LES	4,000	6" FLG	1,638	200	PCC148004HT97
5700 NRG-LES	5,700	8" FLG	2,048	285	PCC172006HT129
7400 NRG-LES	7,400	8" FLG	2,867	370	PCC196008HT129
9400 NRG-LES	9,400	8" FLG	3,686	470	PCC196008HT129

* Flow based on 100 PSIG, 85°F cooling water and 300°F max. compressor outlet. Consult factory for other conditions.

System ΔP<8.0 all models. (Includes dryer, cooler, separator, and afterfilter.)

SPX PNEUMATIC PRODUCTS

DISTRIBUTED BY

4647 SW 40th Avenue
 Ocala, Florida 34474-5799
 Tel (352) 237-5500
 Fax (352) 873-5187
 E-Mail pneumatic.products.sales@airtreatment.spx.com
 Web www.pneumaticproducts.com

©Pneumatic Products 2003
 PIS-138c 9/03

Because of our policy of continuous improvement, some information, specifications and dimensions contained herein may be revised. For confirmed accuracy, always refer to factory submittals.